

## 主要特征 Main Feature

- 60A 高触点负载能力。  
Low 60 a high contact load capacity.
- 切换功率 15KVA。  
Low switching power 15 kva.
- 功耗低，省电型。  
Low power consumption, save electricity.
- 强耐冲击，可靠性高。  
Strong impact resistance, high reliability.
- 寿命长。  
"Life is long.
- 可提供单线圈和双线圈继电器。  
Can provide one coil with double coil relay.

## 使用须知 Use The Information

- 磁保持继电器出厂状态为触点闭合状态（复位状态），但因运输或继电器安装时受到冲击等因素的影响，可能会改变状态，因此在使用前有必要采取措施重新使其复位。  
Low magnetic stick relay factory status to contact closure state (reset state), but because of the transportation or relay hit when installation, the influence of such factors as may change state, so it is necessary to take measures before use to make its reset.
- 为了确保磁保持继电器可靠动作，施加到线圈上的激励电压须达到额定值，且脉冲宽度须达到动作时间的 3 倍以上。对于双线圈继电器，不要同时向两个线圈施加电压信号，也不要长时间（大于 1 分钟）向线圈施加电压，以防线圈过热损坏。  
Low magnetic stick relay in order to ensure reliable action, must be applied to the coil excitation voltage rating, and the action time of the pulse width must be more than 3 times. For double coil relay, not to the two coil voltage signal at the same time, also don't long time (more than 1

## ISO9001、ISO14001 Certification Enterprises

minute) to the coil voltage, in case of damage of coil overheating.

- 不带软铜编织线的磁保持继电器，负载引出脚不能锡焊，不能随意扳动，且不能同时刚性固定两个引出脚。  
Low with no soft braided copper wire magnetic hold relay, load leads to feet can't soldering, not casually throw, and cannot be rigidly two lead foot at the same time.
- 继电器入厂检查及使用中应轻拿轻放，防止跌落影响参数。入厂作破坏性检查的产品要与正常产品严格区分标识，不得装机使用。

In low relay incoming inspection and use to should take put down gently, prevent dropping impact parameters.

The factory as a destructive testing product strictly distinguish with normal logo, may not be installed to use.

主

## 触点参数 Contact Parameter

- 触点形式(Contact Form).....1B
- 触点材料(contact material) .....银合金 silver alloy
- 接触压降(contact voltage drop) .....MAX.15mV
- 触点负载（阻性）  
(Contact load (resistance)) .....80A 250VAC
- 最大切换电压(Largest switching voltage) .....250VAC
- 最大切换电流(Maximum Switching Current) .....80A
- 最大切换功率(MaxSwitchingPower) .....15000VA
- 寿命(life): 电气(electrical) .....1×10<sup>4</sup> Ops  
机械(Machine) .....5×10<sup>5</sup> Ops

## 特性参数 Characteristic Parameter

- 闭合时间(making time) ..... MAX. 20mS
- 断开时间(turn off time) .....MAX. 20mS
- 介质耐压(Dielectric Strength):  
断开触点间(Between  
Contacts) .....1,500VAC(50/60Hz,1Min)  
线圈与触点间(Between coil and  
contact) .....4,000VAC (50/60Hz,1Min)
- 绝缘电阻(500VDC)(Insulation resistance (500  
VDC)) .....500MΩ Min.
- 重量(未含附件)(Weight (not including the  
attachment)) .....40g
- 外形安装尺寸(Mounting Dimension) .....  
见外形结构图(See appearance structure)

订货标记 (型号命名规则) Ordering tags (model naming rules)

**BMC - B - 80A - L1 - 12VDC**

线圈电压: 5V、6V、9V、12V、24V、48V

Coil voltage 5 v 6 v, 9 v 12 v and 24 v, 48 v

L1:单线圈 L2:双线圈

L1: one coil L2: double coil

负载: 40A、60A、80A、100A

Load: 40 A, 60 A, 80 A, 100 A

触点形式: A: 常开触点 B: 常闭触点

Contact form: A: normally open contacts B: the normally closed contact

继电器品名: BMC

Relay name: BMC

线圈参数(20°C) Coil parameters

额定电压 (VDC) Rated Voltage	线圈电阻(Ω)±10% Coil resistance		线圈功耗(W) Coil power consumption		闭合电压(VDC) sealing voltage	断开电压 (VDC) off voltage	允许过电压 (VDC) allowable common mode overvoltage
	单 Single	双 Double	单 Single	双 Double			
6	36.0	18/18	1.0	2.0	≤4.2	≤4.2	9.0
9	81.0	40.5/40.5			≤6.3	≤6.3	13.5
12	144.0	72/72			≤8.4	≤8.4	18.0
24	576.0	288/288			≤16.8	≤16.8	36.0

环境参数 Environmental Parameter

环境温度 The environment temperature	相对湿度 Relative humidity	振动 vibration	冲击 impact
-40°C ~ +70°C	45%-90% RH	10-55Hz 1.5mm	98m/s <sup>2</sup>

外形结构图 (单位: mm) Contour Chart (unit: mm)

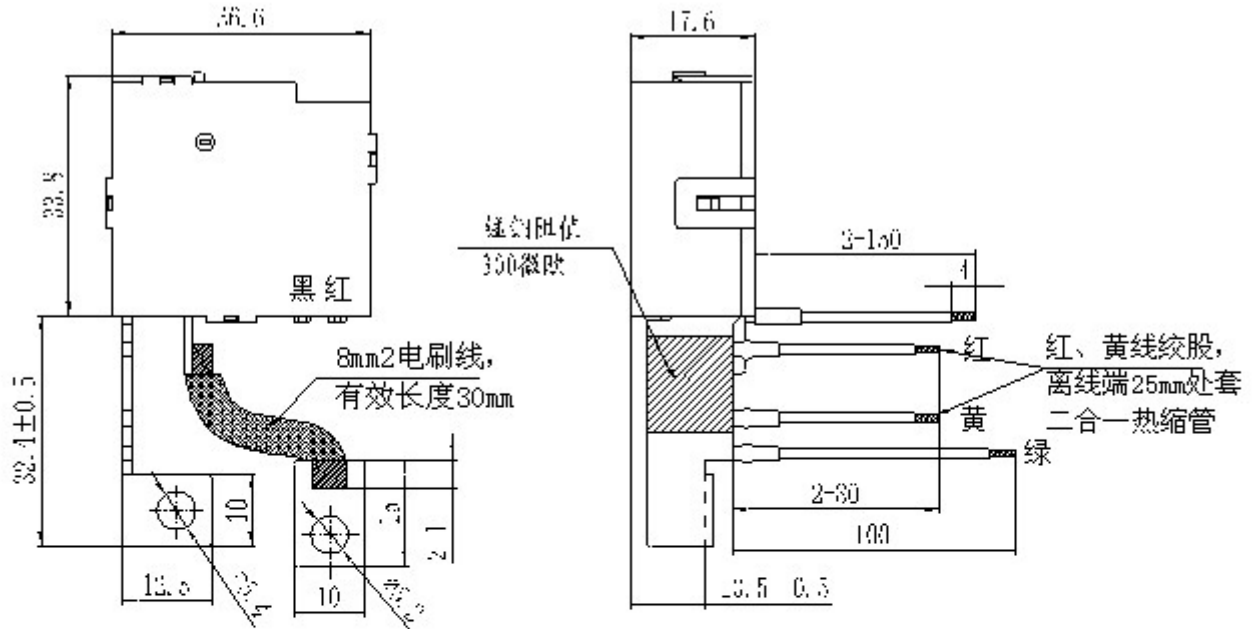

接线图

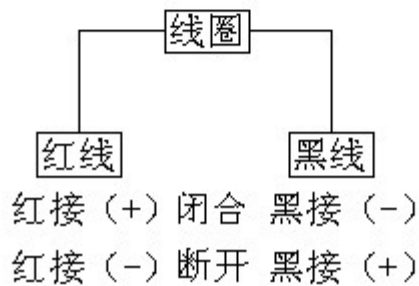

**AFE**

BMC-A-80A-L1  
 80A 250VAC  
 COIL:12VDC  
 MADE IN CHINA

